

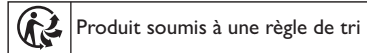

EN - DESIGNED TO SIT NEATLY IN A BATH FOR IMPROVED COMFORT AND SECURITY. ENSURE BATH IS DRY AND FREE FROM SOAP OR OIL FILM. TEST FOR STABILITY. DO NOT USE ON A BATH WITH A TEXTURED SURFACE. IT IS THE RESPONSIBILITY OF THE OWNER TO CARRY OUT AN INITIAL AND REGULAR RISK ASSESSMENTS.

FR - CONÇU POUR S'ASSOIR PARFAITEMENT DANS UNE BAIGNOIRE POUR UN CONFORT ET UNE SÉCURITÉ AMÉLIORÉS. VÉRIFIER QUE LA BAIGNOIRE EST SÈCHE ET NE CONTIENT NI SAVON NI PELLICULE GRASSE. TESTER LA STABILITÉ. NE PAS UTILISER SUR UN BAIN À SURFACE TEXTURÉE. IL EST DE LA RESPONSABILITÉ DU PROPRIÉTAIRE DE PROCÉDER À UNE ÉVALUATION INITIALE ET RÉGULIÈRE DES RISQUES.



DE - ENTWURF, ORDENTLICH IN EINEM BAD ZU SITZEN FÜR VERBESSERTEN KOMFORT UND SICHERHEIT. SICHERSTELLEN, DASS DIE BADEVANNE TROCKEN UND VON SEIFEN- ODER ÖLFILM FREI IST. AUF STABILITÄT PRÜFEN. NICHT AUF EINEM BAD MIT STRUKTURIERTER OBERFLÄCHE VERWENDEN. ES LIEGT IN DER VERANTWORTUNG DES EIGENTÜMERS, EINE ERSTE UND REGELMÄßIGE RISIKOBEWERTUNG DURCHZUFÜHREN.

IT - PROGETTATO PER SEDERSI ORDINATAMENTE IN UNA VASCA DA BAGNO PER UN MAGGIORE COMFORT E SICUREZZA. ASSICURATEVI CHE LA VASCA DA BAGNO SIA ASCIUTTA E PRIVA DI RESIDUI DI SAPONE O DI DETERGENTI OLEOSI. VERIFICATE LA STABILITÀ. NON UTILIZZARE SU UNA VASCA DA BAGNO CON UNA SUPERFICIE RUVIDA. È RESPONSABILITÀ DEL PROPRIETARIO EFFETTUARE UNA PRIMA E REGOLARE VALUTAZIONE DEI RISCHI.

ES - DISEÑADO PARA SENTARSE ORDENADAMENTE EN UN BAÑO PARA MAYOR COMODIDAD Y SEGURIDAD. ASEGÚRESE DE QUE LA BAÑERA ESTÉ SECA Y LIBRE DE JABÓN O PELÍCULAS DE ACEITE. COMPRUEBE SU ESTABILIDAD. NO LO USE EN UN BAÑO CON UNA SUPERFICIE TEXTURIZADA. ES RESPONSABILIDAD DEL PROPIETARIO REALIZAR EVALUACIONES DE RIESGO INICIALES Y PERIÓDICAS.

NL - ONTWORPEN OM NETJES IN EEN BAD TE ZITTEN VOOR MEER COMFORT EN VEILIGHEID. ZORG DAT HET BAD DROOG, ZEEPEN VETVRIJ IS. TEST OF DE BADVERKORTER STABIEL IS. NIET GEBRUIKEN OP EEN BAD MET EEN GESTRUCTUREERD OPPEERVLAK. HET IS DE VERANTWOORDELIJKHEID VAN DE EIGENAAR OM EEN EERSTE EN REGELMATIGE RISICOOORDELING UIT TE VOEREN.

PT - PROJETADO PARA SENTAR-SE PERFEITAMENTE EM UMA BANHEIRA PARA MAIOR CONFORTO E SEGURANÇA. ASSEGURE-SE DE QUE A BANHEIRA ESTÁ SECA E LIMPA, SEM SABÃO NEM ÓLEO. TESTE A ESTABILIDADE. NÃO USE EM UM BANHO COM UMA SUPERFÍCIE TEXTURIZADA. É RESPONSABILIDADE DO PROPRIETÁRIO REALIZAR UMA AVALIAÇÃO DE RISCO INICIAL E REGULAR.

DK - DESIGNET TIL AT SIDDE PÆNT I ET BAD FOR FORBEDRET KOMFORT OG SIKKERHED. SØRG FOR, AT BADET ER TØRT OG FRI FOR SÆBE ELLER OLIEFILM. TEST FOR STABILITET. BRUG IKKE PÅ ET BAD MED EN STRUKTURERET OVERFLADE. DET ER EJERENS ANSVAR AT FORETAGE EN INDLEDENDE OG REGELMÆSSIG RISIKOVURDERING.

SV - UTFORMAD FÖR ATT SITTA SNYGGT I ETT BAD FÖR BÄTTRE KOMFORT OCH SÄKERHET. SE TILL ATT BADEKARET ÄR TORRT OCH FRITT FRÅN TVÅL- ELLER OLJEFILM. KONTROLLERA ATT DEN SITTER STABILT. ANVÄND INTE PÅ ETT BAD MED EN TEXTURERAD YTA. DET ÄR ÄGARENS ANSVAR ATT GENOMFÖRA EN FÖRSTA OCH REGELBUNDEN RISKBEDÖMNING.

NO - DESIGNET FOR Å SITTE PÆNT I ET BADEKAR FOR FORBEDRET KOMFORT OG SIKKERHET. FORSIKRE DEG OM AT KARET ER RENT OG FRITT FOR SÅPE ELLER OLJELEGG. TEST FOR STABILITET. IKKE BRUK PÅ ET BAD MED EN STRUKTURERT OVERFLATE. DET ER EIERENS ANSVAR Å FORETA EN INNLEDENDE OG REGELMESSIG RISIKOVURDERING.

FI - SUUNNITELTU ISTUMAAN SIISTISTI KYLPYYN MUKAVUUDEN JA TURVALLISUUDEN PARANTAMISEKSI. VARMISTA, ETTÄ KYLPYAMME ON KUIVA JA ETTÄ SEN PINNASSA EI OLE SAIPPUA- TAI ÖLJYKALVOA. VARMISTA, ETTEI SE PÄÄSE LIUKUMAAN. ÄLÄ KÄYTÄ KYLPYYN, JOLLA ON KUVIOITU PINTA. OMISTAJAN VASTUULLA ON SUORITTA A LUSTAVAJA JA SÄÄNNÖLLINEN RISKINARVIOINTI.

EL - ΣΧΕΔΙΑΣΜΕΝΟ ΓΙΑ ΝΑ ΤΑΚΤΟΠΟΙΕΙΣΤΕ ΣΤΟ ΜΠΑΝΙΟ ΓΙΑ ΒΕΛΤΙΩΜΕΝΗ ΑΝΕΣΗ ΚΑΙ ΑΣΦΑΛΕΙΑ. ΒΕΒΑΙΩΘΕΙΤΕ ΩΣΤΕ ΤΟ ΜΠΑΝΙΟ ΕΙΝΑΙ ΣΤΕΓΝΟ ΚΑΙ ΧΩΡΙΣ ΣΑΠΟΥΝΙ Η ΤΑΙΝΙΑ ΛΑΔΙΟΥ. ΕΞΕΤΑΣΤΕ ΓΙΑ ΣΤΑΘΕΡΟΤΗΤΑ. ΜΗΝ ΤΟ ΧΡΗΣΙΜΟΠΟΙΕΙΤΕ ΣΕ ΜΠΑΝΙΕΡΑ ΜΕ ΨΗΦΙ ΕΠΙΦΑΝΕΙΑΣ. ΕΙΝΑΙ ΕΥΘΥΝΗ ΤΟΥ ΙΔΙΟΚΤΗΤΗ ΝΑ ΔΙΕΝΕΡΓΕΙ ΜΙΑ ΑΡΧΙΚΗ ΚΑΙ ΤΑΚΤΙΚΗ ΕΚΤΙΜΗΣΗ ΚΙΝΔΥΝΟΥ.

i Triman - Indicates recycling and sorting rules (only relevant for France)



VIEW THE ENTIRE RANGE ONLINE AT
GORDONELLISHEALTHCARE.CO.UK

[gordonellis.healthcare](https://www.gordonellis.healthcare)
 @EllisHealthcare



DERBY® IN BATH SEAT

Welcome to your new Gordon Ellis product.
 We hope that it proves a useful aid in your daily life.



SEE INSIDE AND REVERSE FOR FITTING INSTRUCTIONS
 AVAILABLE IN THE FOLLOWING LANGUAGES:
 EN FR DE IT ES NL PT DK SV NO FI EL



MAXIMUM USER WEIGHT	POIDS MAXIMUM DE L'UTILISATEUR
MAXIMALES BENUTZERGEWICHT	PESO MASSIMO SOPPORTATO
MAXIMUMGEWICHT VAN GEBRUIKERS	PESO MÁXIMO DE USO
HÖGSTA ANVÄNDARVIKT	MAKSIMUM BRUKERVEKT
ΑΝΩΤΑΤΟ ΟΠΙΟ ΒΑΡΟΥΣ ΤΟΥ ΧΡΗΣΤΗ	ΜΑΧ. ΒΡΥΓΕΡVÆΓΤ
	SUURIN KÄYTTÖPAINO



EN ANY SERIOUS ACCIDENT OCCURRING THROUGH USE SHOULD BE REPORTED TO THE MANUFACTURER - CONTACT DETAILS BELOW
FR TOUT ACCIDENT GRAVE SURVENANT PENDANT L'UTILISATION DOIT ÊTRE SIGNALÉ AU EC REP - COORDONNÉES CI-DESSOUS
DE JEDER SCHWERE UNFALL WÄHREND DES GEBRAUCHS MUSS EC REP GEMELDET WERDEN - KONTAKTDATEN UNTEN
IT QUALSIASI INCIDENTE GRAVE CHE SI VERIFICA DURANTE L'USO DEBE ESSERE SEGNALATO AL PRODUTTORE - DETTAGLI DI CONTATTO DI SEGUITO
ES CUALQUIER ACCIDENTE GRAVE QUE OCURRA DURANTE EL USO DEBE INFORMARSE A EC REP - DETALLES DE CONTACTO A CONTINUACIÓN
NL ELK ERNSTIG ONGEVAL TIJDENS HET GEBRUIK MOET WORDEN GEMELD AAN EC REP - CONTACTGEGEVENS HIERONDER
PT QUALQUER INCIDENTE SÉRIO QUE OCORRA DURANTE O USO DEVE SER RELATADO AO FABRICANTE - DETALHES DE CONTACTO ABAIXO
DK ENHVER ALVORLIG HÆNDELSE, DER OPSTÅR UNDER BRUG, SKAL RAPPORTERES TIL PRODUKTEN - KONTAKTOPPLYSNINGER NEDENFOR
SV ALLA ALLVARLIGA HÄNDELSER SOM INTRÄFFAR UNDER ANVÄNDNING MÅSTE RAPPORTERAS TILL TILLVERKAREN - KONTAKTUPPGIFTER NEDAN
NO ENHVER ALVORLIG HENDELSE SOM OPSTÅR UNDER BRUK MÅ RAPPORTERES TIL PRODUSENTEN - KONTAKTINFORMASJON NEDENFOR
FI KÄIKISTÄ KÄYTTÖN AIKANA TAPAHTUNEISTA VAKAVISTA TAPAHTUMISTA ON ILMOITETTAVA VALMISTAJALLE - YHTEYSTIEDOT ALLA
EL ΚΑΘΕ ΣΟΒΑΡΟ ΣΥΜΒΑΝ ΠΟΥ ΕΜΦΑΝΙΖΕΤΑΙ ΚΑΤΑ ΤΗ ΧΡΗΣΗ ΠΡΕΠΕΙ ΝΑ ΑΝΑΦΕΡΕΤΑΙ ΣΤΟΝ ΚΑΤΑΣΚΕΥΑΣΤΗ - ΠΑΡΑΚΑΤΩ ΣΤΟΙΧΕΙΑ ΕΠΙΚΟΙΝΩΝΙΑΣ

Your **DERBY® IN BATH SEAT** was specifically developed by our UK Design Team with the intention of compensating for an injury, or overcoming a temporary or permanent disability. Hopefully making daily living that little bit easier.



DESIGNED & MADE IN THE UK



MD



IFU-REF 6006/W/1120-3



GORDON ELLIS & CO.
 TRENT LANE
 CASTLE DONNINGTON
 DERBY. ENGLAND DE74 2AT

REF 6006/W + 6008/W

EC REP

AUTHORISED REPRESENTATIVE
 ADVENA LTD, TOWER BUSINESS CENTRE, 2ND FLOOR, TOWER STREET, SWATAR, BKR 4013 MALTA

VIEW THE ENTIRE RANGE ONLINE AT
GORDONELLISHEALTHCARE.CO.UK

[gordonellis.healthcare](https://www.gordonellis.healthcare)
 @EllisHealthcare



1 FITTING INSTRUCTIONS

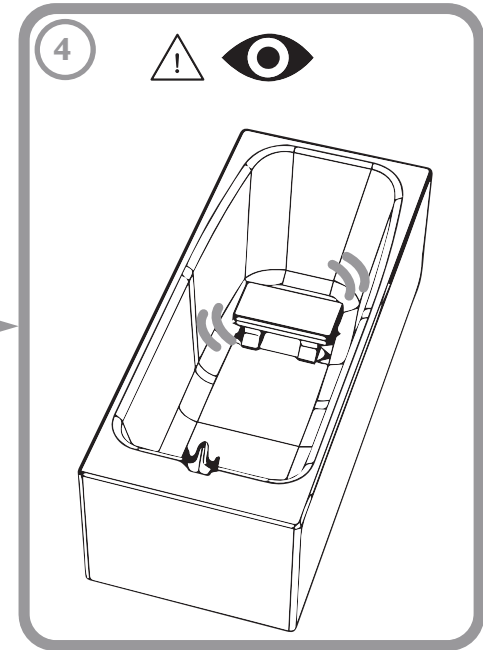
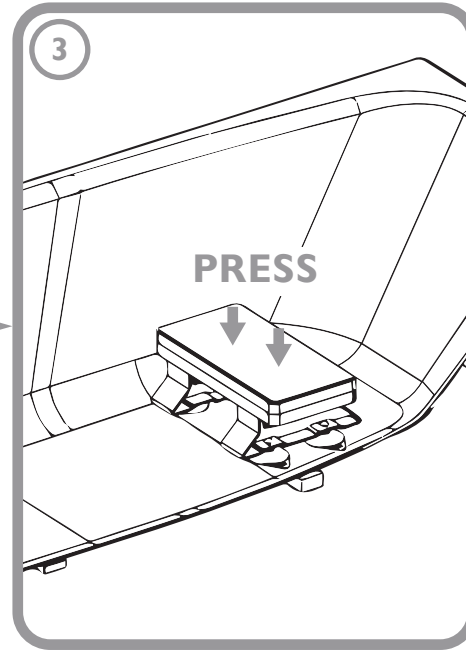
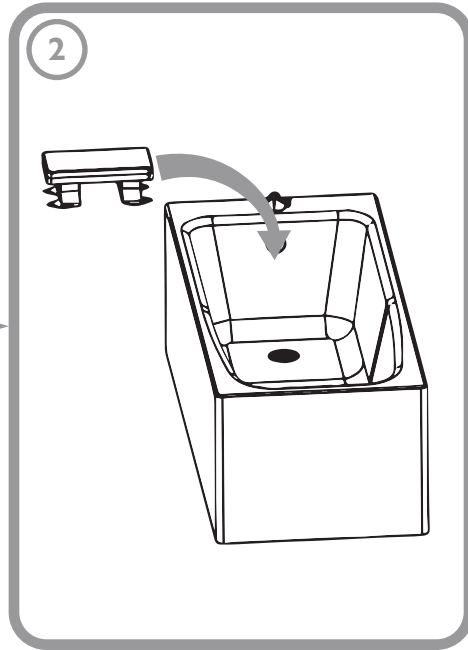
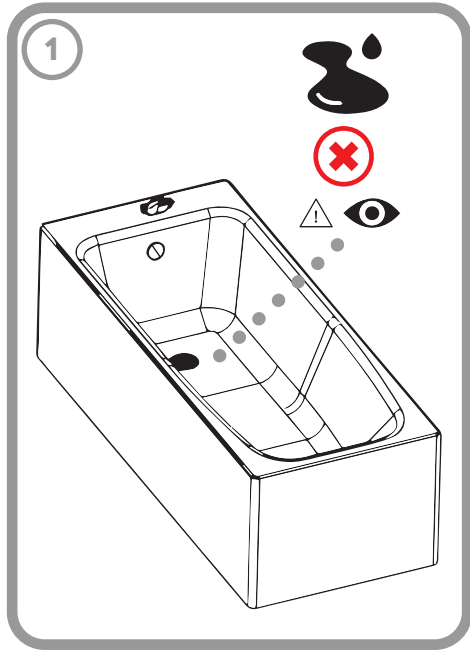

1 REMOVAL INSTRUCTIONS

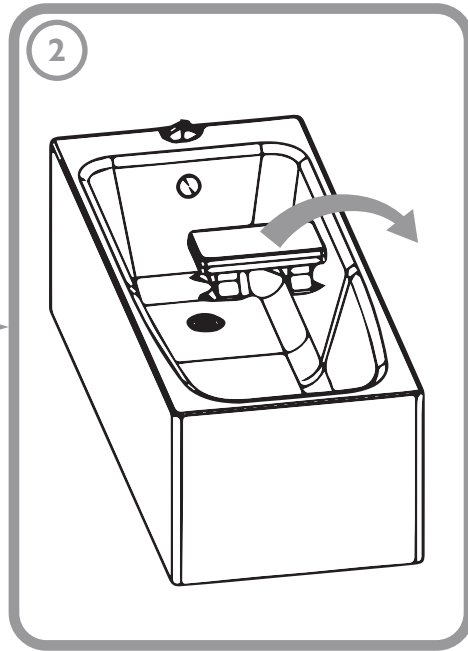
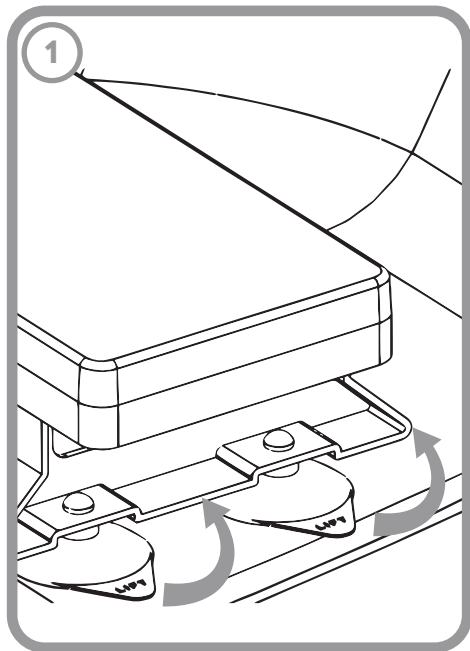

1 CLEANING INSTRUCTIONS



CLEANING INSTRUCTIONS
ISTRUZIONI PER LA PULIZIA
INSTRUÇÕES DE LIMPEZA
RENGJØRINGSINSTRUKSJONER
INSTRUCTIONS DE NETTOYAGE
INSTRUCCIONES DE LIMPIEZA

RENGØRINGSINSTRUKTIONER
PUHDISTUSOHJEET
REINIGUNGSANWEISUNGEN
SCHOONMAAK INSTRUCTIES
RENGØRINGSINSTRUKTIONER
ΟΔΗΓΙΕΣ ΚΑΘΑΡΙΣΜΟΥ

PH 5 - 9

EN WIPE DOWN WITH A NON-ABRASIVE CLOTH AND SOAPY WATER.
FR ESSUYEZ AVEC UN CHIFFON NON ABRASIF ET DE L'EAU SAVONNEUSE.
DE MIT EINEM NICHT SCHEUERNDEN TUCH UND SEIFENWASSER ABWISCHEN.
IT PULIRE CON UN PANNONON ABRASIVO E ACQUA SAPONOSA.
ES LIMPIELO CON UN PAÑO NO ABRASIVO Y AGUA CON JABÓN.
NL AFNEMEN MET EEN NIET-SCHURENDE DOEK EN ZEEPACHTIG WATER.
PT RETIRAR COM PANO NÃO ABRASIVO E ÁGUA COM SABÃO.
DK AFTØRRES MED EN IKKE-SLIBENDE KLUD OG SÆBEVAND.
SV TORKA AV MED EN IKKE-SLIPANDE TRASA OCH TVÅLVATTEN.
NO TØRK AV MED EN IKKE-SLIPENDE KLUT OG SÅPEVANN.
FI PYYHI HANKAAMATTOMALLA LIINALLA JA SAIPUUNVEDELLÄ.
EL ΣΚΟΥΠΙΣΤΕ ΜΕ ΕΝΑ ΜΗ ΛΕΙΑΝΤΙΚΟ ΠΑΝΙ ΚΑΙ ΣΑΠΟΥΝΟΝΕΡΟ.